



GARDEN/POOL SHED

English

Assembly instructions

REMISE DE JARDIN/PISCINE

Français

Instructions de montage

GARTEN/SCHWIMMBADSCHUPPEN

Deutsch

Montageanleitung

COBERTIZO DE JARDIN/PISCINA

Español

Instrucciones de ensamble

TUIN / ZWEMBADBERGING

Nederlands

Montagehandleiding

MAGAZZINO DA GIARDINO/PISCINA

Italiano

Istruzioni di montaggio

ABRIGO DE JARDIM/PISCINA

Português

Instruções de montagem

Customer service • Service clientèle • Kundenservice
Servicio al cliente • Klantenservice
Servizio consumatori • Serviço ao cliente

USA: Call Toll Free Number: 1-(888)-374-4262 Fax: 315-575-4502
11495 North Pennsylvania Suite 110, Carmel, Indiana 46032, U.S.A

Canada: Call Toll Free Number: Appel gratuit: 1-(800)-661-6721

United Kingdom: Keter (UK) Ltd.

Unit 4, Woodgate Business Park, Clapgate Lane,
Birmingham, B32 - 3DB, United Kingdom.

Tel: 0121-5060008, Fax: 0121-4220808

Other European Countries: Keter Europe Gardening
Ericssonstraat 17, Postbus 224, 5120 AE Rijen, the Netherlands.

Tel: 31-1612-28301, Fax: 31-1612-28322

www.outstanding-keter.com

- ▶ Tools, accessories and shelves in illustration are not included.
- ▶ Les outils, accessoires et étagères figurant sur l'illustration ne sont pas inclus.
- ▶ Werkzeuge, Zubehör und Regale auf den Abbildungen sind nicht mit inbegriffen.
- ▶ No se incluyen las herramientas, accesorios y estanterías de la ilustración.
- ▶ Gereedschap, hulpmiddelen en planken in de illustratie zijn niet inbegrepen.
- ▶ Gli attrezzi, gli accessori e gli scaffali nell'illustrazione non sono inclusi.
- ▶ Ferramentas, acessórios e prateleiras na ilustração não estão incluídos.

OutStanding

by KETER®

A-220-6
502237



Assembly parts • Pièces à assembler • Montageteile • Piezas de ensamble Onderdelen • Parti di assemblaggio • Peças de montagem

GX1

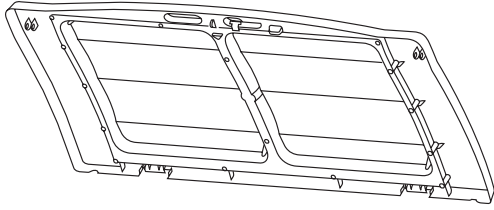

DX1

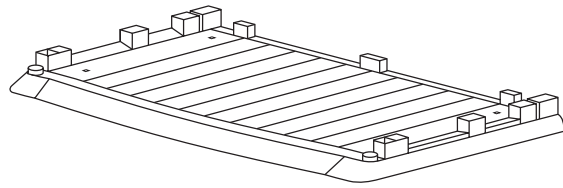

BX1

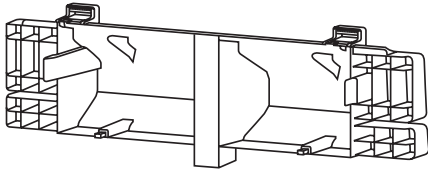

AX1

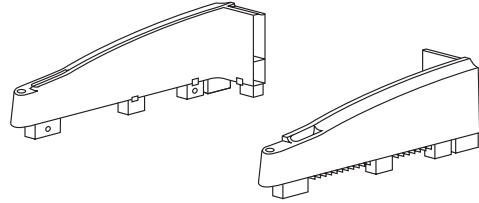

XX1

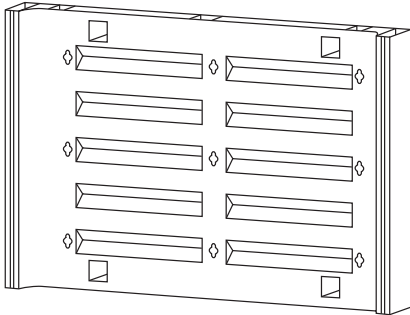

CX1

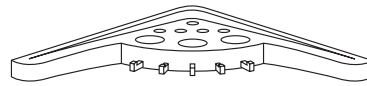

JX2

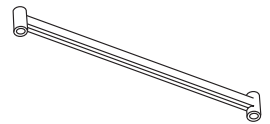

EX2

LHX1

RHX1

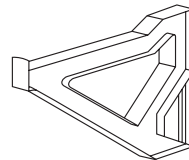
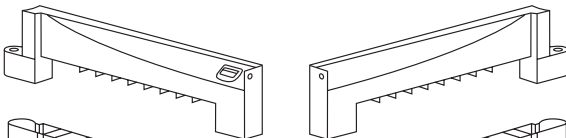

MX2

SX2

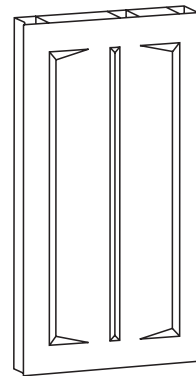

LX1

RX1

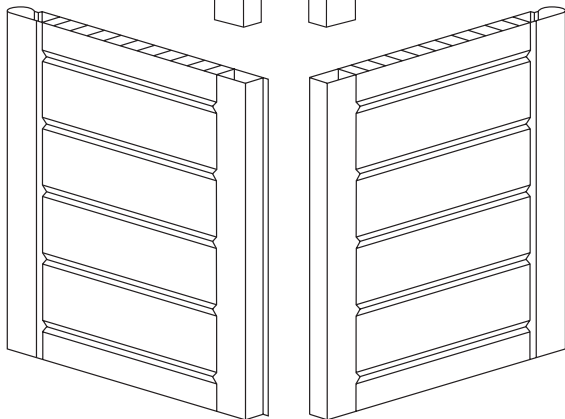

PX2



W1X13



W2X17



W3X4



IMPORTANT:
Please contact
Customer
Service if you
have any
problems or
discover any
missing parts.

WICHTIG:
Bitte wenden Sie
sich an unseren
Kundenservice, falls
Sie irgendwelche
Probleme haben
oder feststellen, daß
Teile fehlen.

BELANGRIJK:
Neemt u in geval
van problemen
of missende
onderdelen
a.u.b. contact op
met de
klantenservice.

IMPORTANT:
Veuillez
contacter notre
Service
Clientèle pour
tout problème ou
pièce
manquante.

IMPORTANTE:
Sírvese contactar
nuestro Servicio al
Cliente
para cualquier
problema, o pieza
que pudiera
faltar.

IMPORTANTE:
In caso di problemi
o di pezzi
mancanti, siete
pregati di mettervi
in contatto con il
servizio
consumatori.

IMPORTANTE:
favor entrar em
contato com o
Serviço ao
Cliente se
houver
problemas ou
se faltar peças.

1

Recommendation: For easier assembly use lubricant on parts to be assembled (e.g. silicon spray or petroleum jelly).

Conseil: Pour faciliter l'assemblage, appliquez un lubrifiant (silicone, vaseline, etc.) sur les pièces à assembler.

Empfehlung: Um den Aufbau zu erleichtern, bitte schmieren Sie die Montageteile leicht mit einem Silikone Spray oder mit Vaseline ein.

Recomendación: Para montar facilmente aplique un lubricante (silicone o vaseline) sobre las piezas a montar.

Aanbeveling: Smeer een smeermiddel op de onderdelen die in elkaar gezet moeten worden, om het in elkaar zetten makkelijker te maken (b.v. silicon spray of petroleum jelly).

Per un montaggio più semplice, **Si raccomanda** de usare del lubrificante sulle parti da montare (p.e. spray al silicone o petrolato).

Recomendação: Para facilitar a montagem use lubrificante nas peças a serem montadas (spray de silicone ou geléia de petróleo).

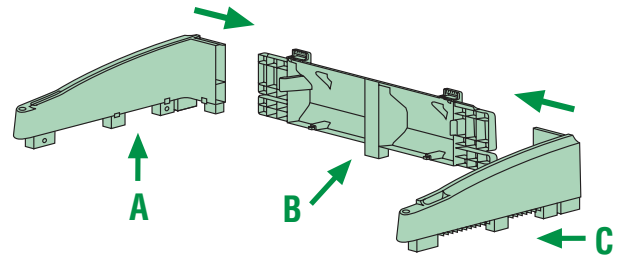
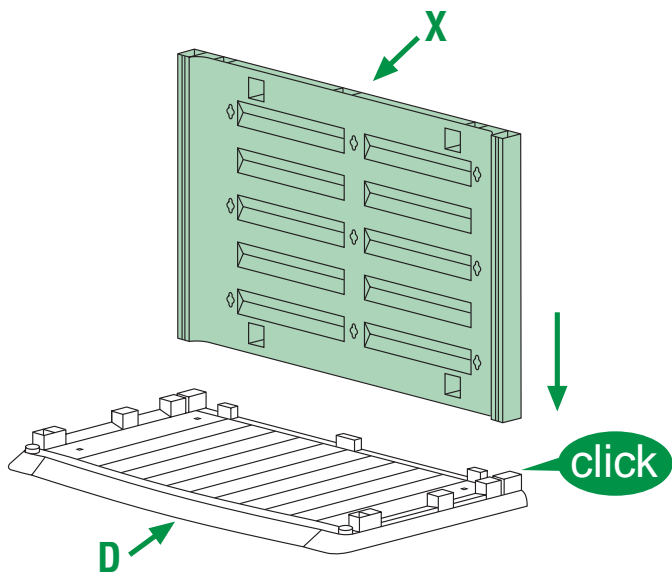
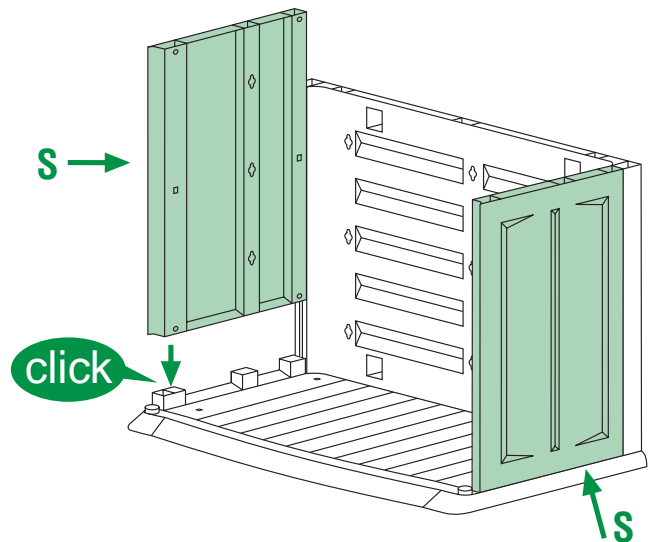
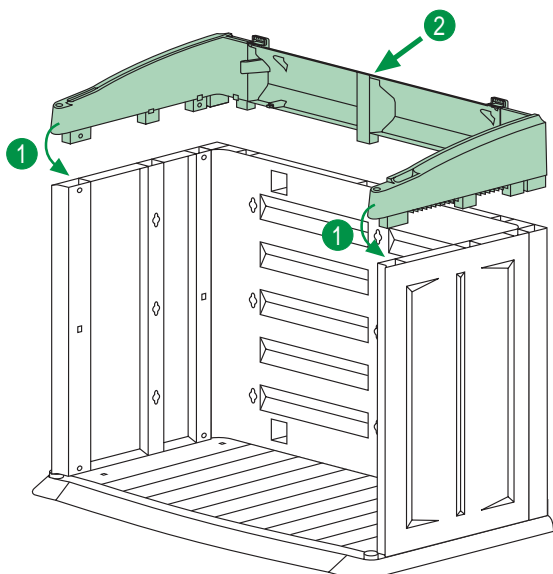
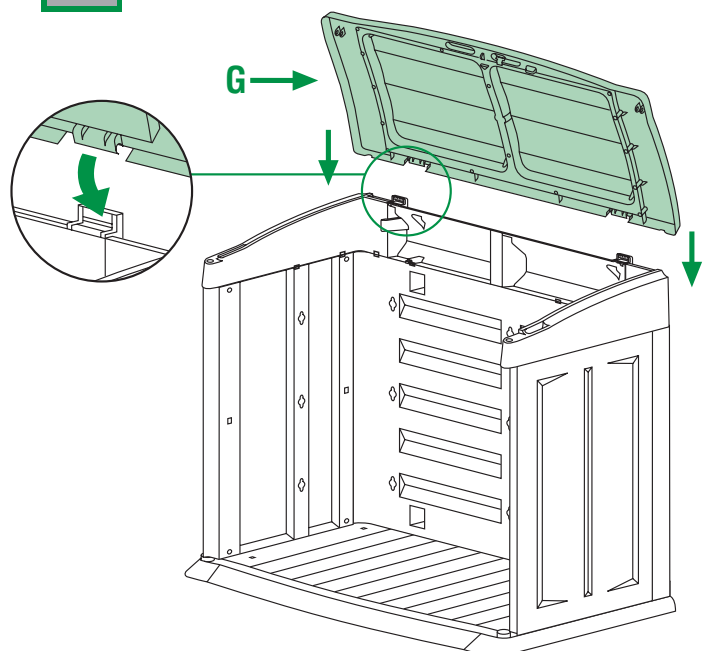
**2****3****4****5**

6

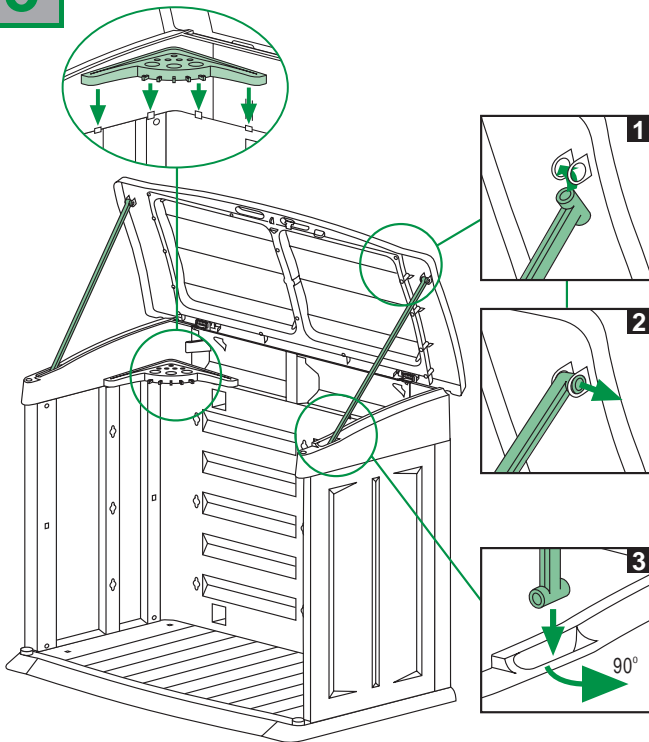

7

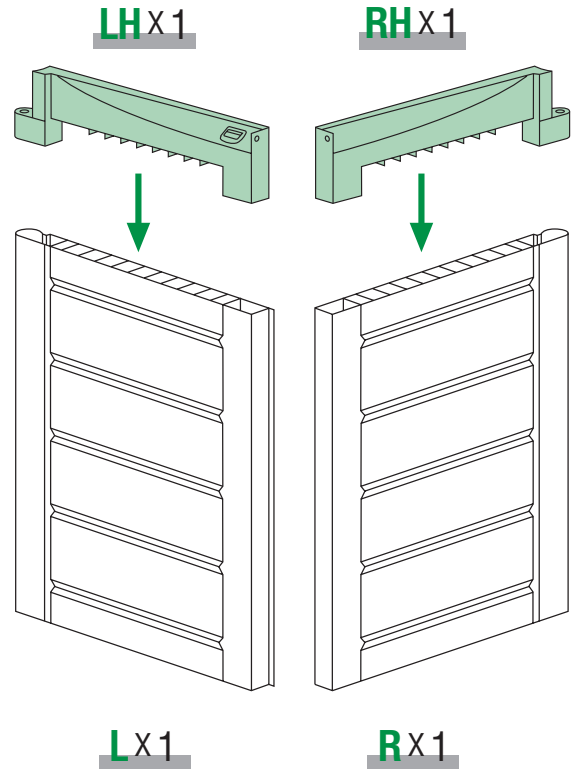

8

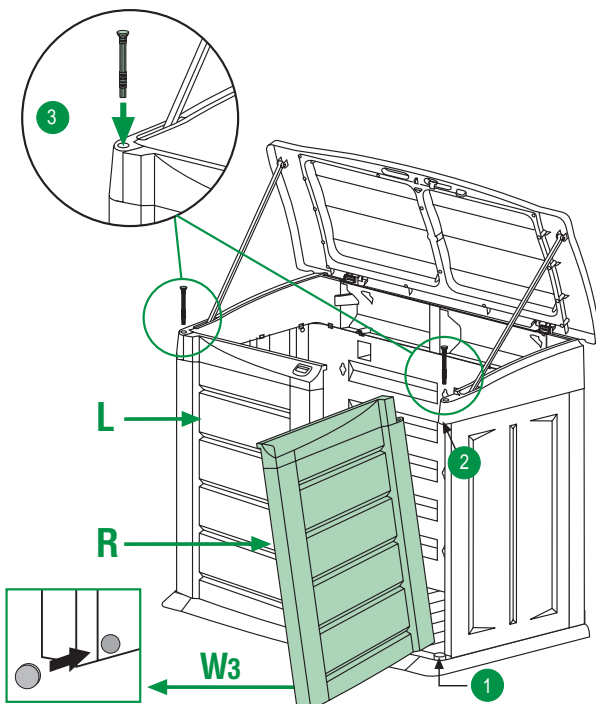

9

- Add caps (W2) also on the back side of the back panel (X).
- Placez également les pastilles (W2) au dos du panneau arrière (X).
- Bringen Sie die Abdeckkappen (W2) auch an der Außenseite der Rückwand (X) an.
- Añada tapones (W2) también en la parte de atrás del panel posterior (X).
- Bevestig de sluitstukken (W2) ook aan de achterkant van het achterpaneel (X).
- Aggiungi i cappucci (W2) anche sul retro del pannello posteriore (X).
- Coloque tampas (W2) también do lado traseiro do painel traseiro (X).

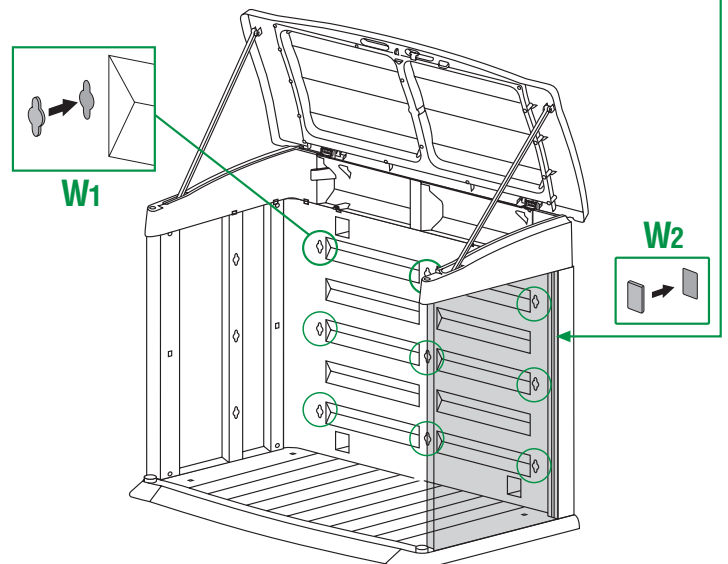

- Lift here to release lid.
- Soulevez à l'endroit indiqué pour ouvrir le couvercle.
- Hier anheben, um den Deckel zu öffnen.
- Alce aquí para soltar la cubierta.
- Hier optillen om het deksel te openen.
- Sollevare qui per aprire il coperchio.
- Levante aqui para soltar a coberta.

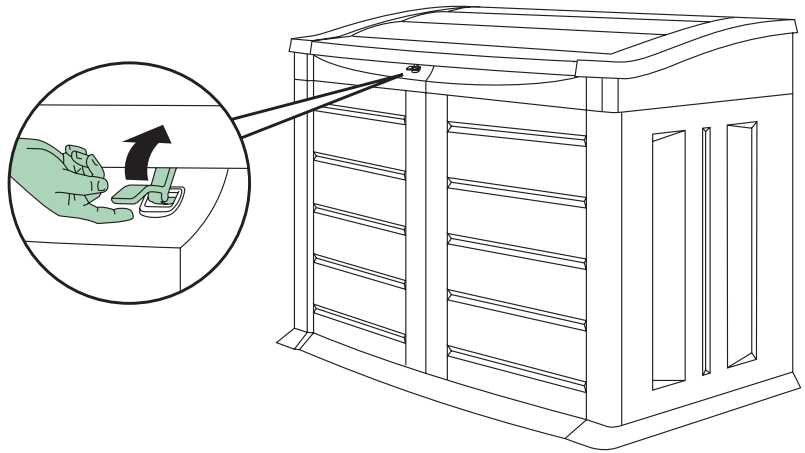

Option

Opción

Optie

Opzione

Opção

A

- It is optional to purchase a Keter shed shelf or a wooden plank and use it as a shelf. After inserting the shelf support (M) into its slot, place the shelf or wooden plank on it.
- Vous pouvez ajouter une étagère de remise de Keter ou une simple planche de bois à votre remise. Insérez le support d'étagère (M) dans la fente destinée à cet effet, et posez dessus l'étagère ou la planche de bois.
- Man kann wahlweise ein Keter Schuppenregal oder eine Holzplatte erwerben und diese als Regal benutzen. Nachdem Sie den Regalträger (M) in seinen Schlitz gesteckt haben, plazieren Sie das Regal oder die Holzplatte darauf.
- Puede comprar un estante para el cobertizo de Keter o una plancha de madera para usar como estante. Despues de insertar el soporte (M) en su lugar, coloque el estante o la plancha encima.
- U kunt een Keter schuurplank, of een houten plank als schap gebruiken. Na de planksteun (M) in het slot te hebben gebracht, kunt u de plank erop leggen.
- E' possibile acquistare uno scaffale apposito per magazzino Keter o una tavola di legno ed usarla come scaffale. Dopo aver inserito il supporto dello scaffale (M) nell' apposita scanalatura, collocarvi lo scaffale o la tavola di legno.
- Pode-se adquirir uma prateleira de abrigo da Keter ou uma tábua de madeira e utilizá-la como uma prateleira. Após inserir o apoio (M) da prateleira na fenda, coloque a prateleira ou a tábua de madeira sobre ele.

1

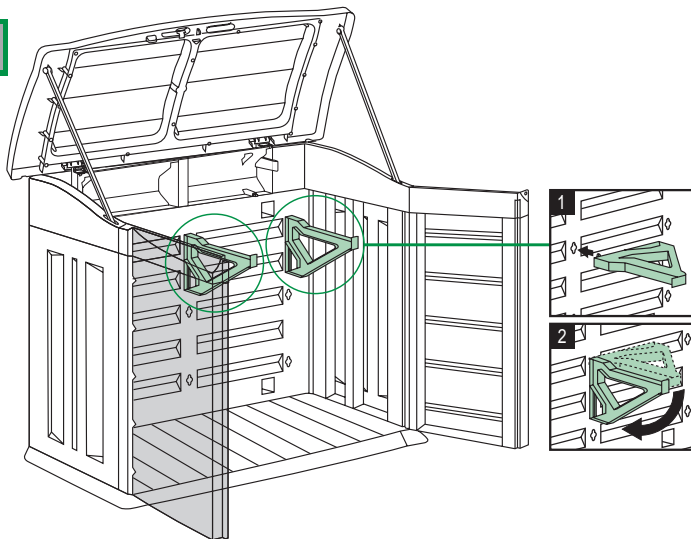

2

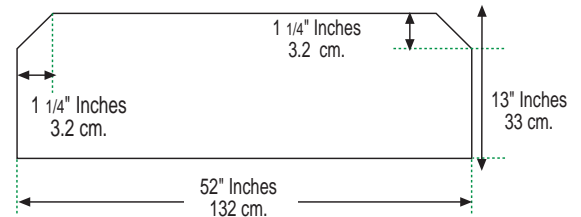
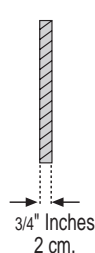
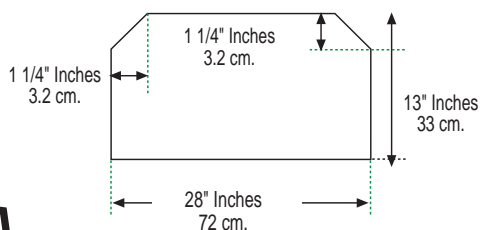
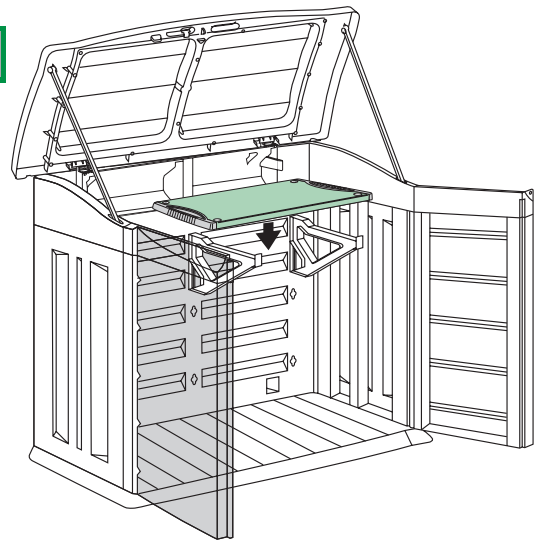

• Bis zu 20kg / 45lb. je Regal • Max. 20kg / 45lb. por estante • Max. 20kg / 45lb. per plank • Max. 20kg / 45lb. per scaffale • Máx. 20kg / 45lb por estante

Option
Opción
Optie
Opzione
Opção

B

- **Recommendation:** Secure Shed to wall and floor.
- **Conseil :** Fixez l'abri de jardin au mur et au sol.
- **Empfehlung:** Schuppen an Boden und Wand befestigen.
- **Recomendación:** Asegure el Cobertizo a la pared y al piso.
- **Aanbeveling:** Bevestig de het schuurtje stevig aan de muur en de vloer.
- **Si raccomanda:** i fissare il magazzino alla parete e al pavimento.
- **Recomendação:** Fixe o abrigo na parede e assoalho.

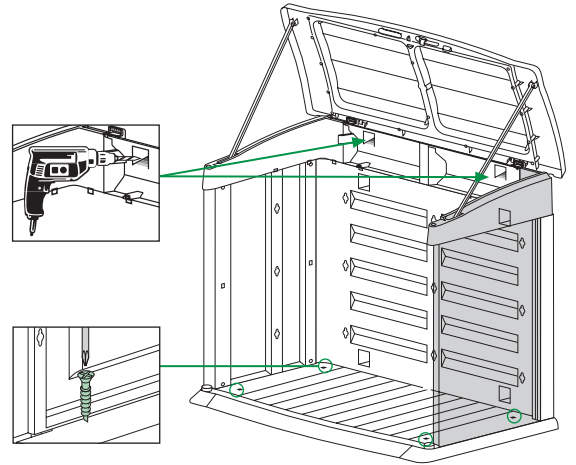

Option
Opción
Optie
Opzione
Opção

C

- It is recommended to attach a latch to the inside bottom of the left door panel (as illustrated).
- Il est recommandé de fixer un loquet au bas de la porte gauche, côté intérieur (voir illustration).
- Wir empfehlen, einen Riegel an der unteren Innenseite des linken Türflügels (siehe Abbildung) anzubringen.
- Se sugiere añadir una traba en la parte interior del borde inferior del panel izquierdo de la puerta (véase la ilustración).
- Het is aan te raden om aan de binnenkant van de linkerdeur een valgrendel te plaatsen (zoals in de illustratie wordt aangegeven).
- È consigliabile fissare un chiavistello nel lato inferiore interno dello sportello sinistro (vedi illustrazione).
- Recomenda-se colocar um bedelho na parte inferior interna do painel esquerdo da porta (veja ilustração).

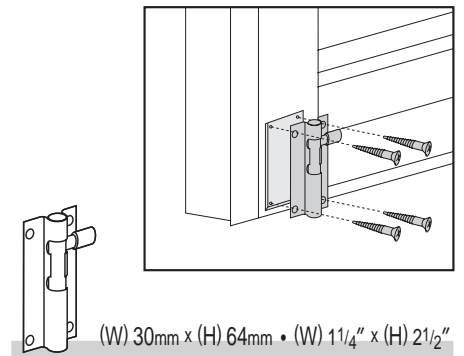

Option
Opción
Optie
Opzione
Opção

D



- Lid lifters - accessory kit
Turns your shed into a functional refuse bin container.
- Kit d'accessoires remonte-couvercles
Transforme votre remise en un abri idéal pour poubelles.
- Deckelheber-Zusatzpackung
Verwandelt Ihren Schuppen in einen praktischen Behälter für Ihren Abfallcontainer.
- Equipo de accesorios alzatapas
Convierte su cobertizo en un contenedor funcional del recipiente de desperdicios.

- Hulpstukkenpakket voor dekselhefinrichting
Verandert uw schuurtje in een bruikbare container voor afvalbakken.
- Kit accessorio Apri-coperchio
Trasforma il tuo magazzino in un funzionale contenitore per rifiuti.
- Kit de acessórios de Levantadores de Tampa
Converte seu abrigo em um recipiente de lata de lixo funcional